

PEM 9 inch Ford Big Bearing Flanged Axle Order Form 636 234-0975 Fax 636 234-0982

Axle Order Information

Type of Application _____

Number of Spline? Check One.

28 spline 31 spline

Axle Offset?

2 1/2" 2 3/8"

Turn Flange OD Max 5.944" _____

Turn Hub Register OD Max 3.06" _____

What type of Housing End? Check One.

Big Ford (Old Style, 1/2" bolt)

Big Ford (New Style Torino, 3/8" bolt)

Driver Side dimensions:

(A) _____

Passenger Side Dimensions:

(A) _____

Maximum axle length is 33"

Minimum axle length is 21.5"

Bolt pattern for wheel?

5 x 4.5" Small 5 x 4.75" GM 5 x 5" Big Ford

Size of Wheel Studs? All wheel studs are Press In.

1/2" Fine Short *5/8" Coarse 2 3/4"

1/2" Fine 3" Long *5/8" Coarse XL 3 3/4"

Access Hole? Yes No

Please Provide Additional Information:

(D) _____

(E) _____

(F) _____

(G) _____

Replacement Bearing also available—9" Ford Axle Large Tapered Bearing Set, 3.15" OD and 1.565" ID.
PEM's part # PA-20set.

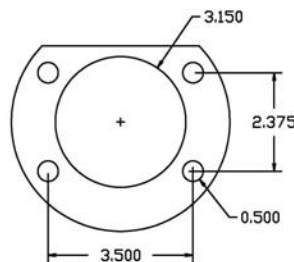
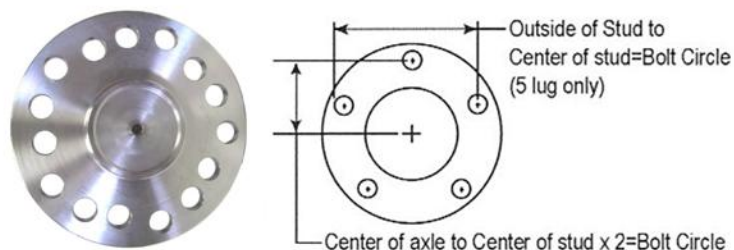
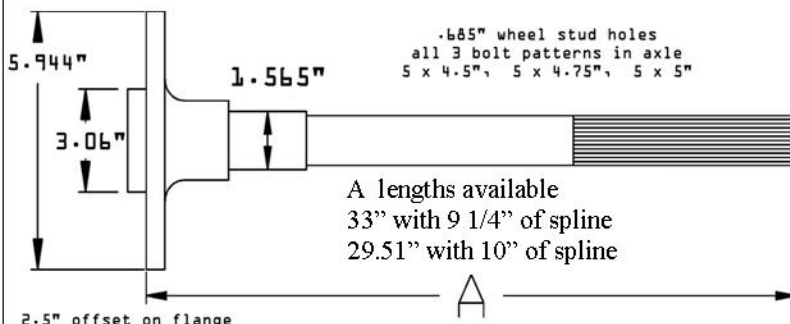

Big Ford (Old Style)

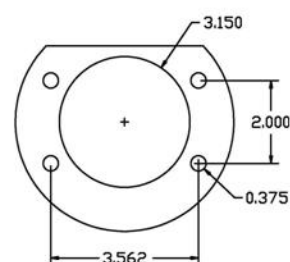

Big Ford (New Style Torino)

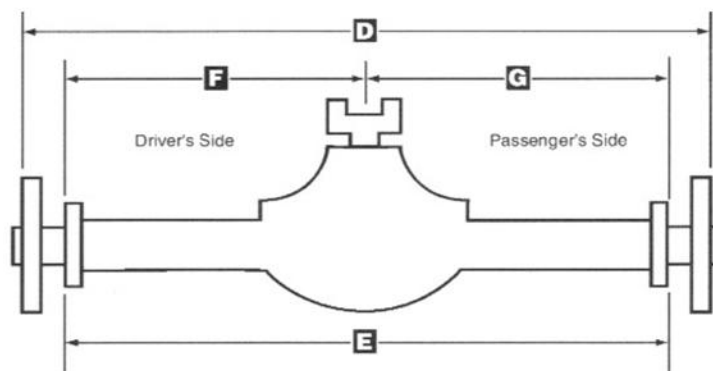

Name _____
Address _____
City _____ State _____ Zip _____
Phone _____ email _____
Signature _____

ALL ORDERS MUST BE ACCOMPANIED WITH COMPLETED FLANGED AXLE ORDER FORM